

ACCUVALVE® MODEL AVT6500 SUBMITTAL

MODEL CODE

⚠ WARNING: NOT FOR USE WITH PERCHLORIC ACID

AVT6 5 - - - -

VALVE HOUSING MATERIAL

5 = PFA COATED 304SS, 20 GAUGE

SIZE

08 = 08" DIAMETER
10 = 10" DIAMETER
12 = 12" DIAMETER
14 = 14" DIAMETER

OPTIONS

BLANK = NO OPTIONS
A = ACCUNET®
B = BACnet MS/TP
F = FLANGES (NOTE 2)
W = WIRELESS BLUETOOTH

ACTUATOR

02 = FAIL LAST POSITION (FLP), 0-10V, 2 SEC
03 = FAIL LAST POSITION (FLP), 2-10V, 2 SEC
04 = FAIL OPEN/CLOSED (FSP), 0-10V, 2 SEC
05 = FAIL OPEN/CLOSED (FSP), 2-10V, 2 SEC

MODEL CODE NOTES:

1. Actuator Type "5" factory default is set to "fail open".
2. Split ring Vanstone Flanges

OPERATING RANGE

Valve Model	Min. Flow Measured			Full Scale Range		
	CFM	L/S	CMH	CFM	L/S	CMH
AVT6508-XX	80	38	136	800	378	1359
AVT6510-XX	120	57	204	1300	613	2209
AVT6512-XX	180	85	306	1790	845	3041
AVT6514-XX	250	118	425	2750	1298	4672

MATERIALS

Materials Exposed to the Airstream	
Housing	PFA Coated, 304 Stainless Steel
Compression Section	PFA Coated, 304 Stainless Steel
Static Regain Section	PFA Coated, 304 Stainless Steel
End Plate	PFA Coated, 304 Stainless Steel
Blades	PFA Coated, 304 Stainless Steel
Shafts	PFA Coated, 316 Stainless Steel
Shaft Bearings	Teflon®
Vortex Sensors	Kynar® PVDF
Sensor Tubing	Viton Rubber
Compression Seals	Viton Rubber
Machine Screws	FEP Coated, 304 Stainless Steel
Rivets	FEP Coated, 304 Stainless Steel
Optional Flanges	FEP Coated, 304 Stainless Steel

SIZE AND WEIGHT

Valve Model	Valve Dimensions						Weight			
	"D"		"L"		"H"		Stainless Steel		Flange Add	
	in.	mm	in.	mm	in.	mm	Lbs.	kg	Lbs.	kg
AVT6508-XX	7.88	200	24	610	13	330	16	7.3	2.6	1.2
AVT6510-XX	9.88	250	24	610	15	381	20	9.1	3.2	1.5
AVT6512-XX	11.88	300	27	686	17	432	26	11.8	4.5	2.0
AVT6514-XX	13.88	350	30	762	19	483	30	13.6	5.2	2.4

SIZE AND WEIGHT NOTES:

1) Round valves with optional flanges "L" is 1/2" (13mm) less than standard valves

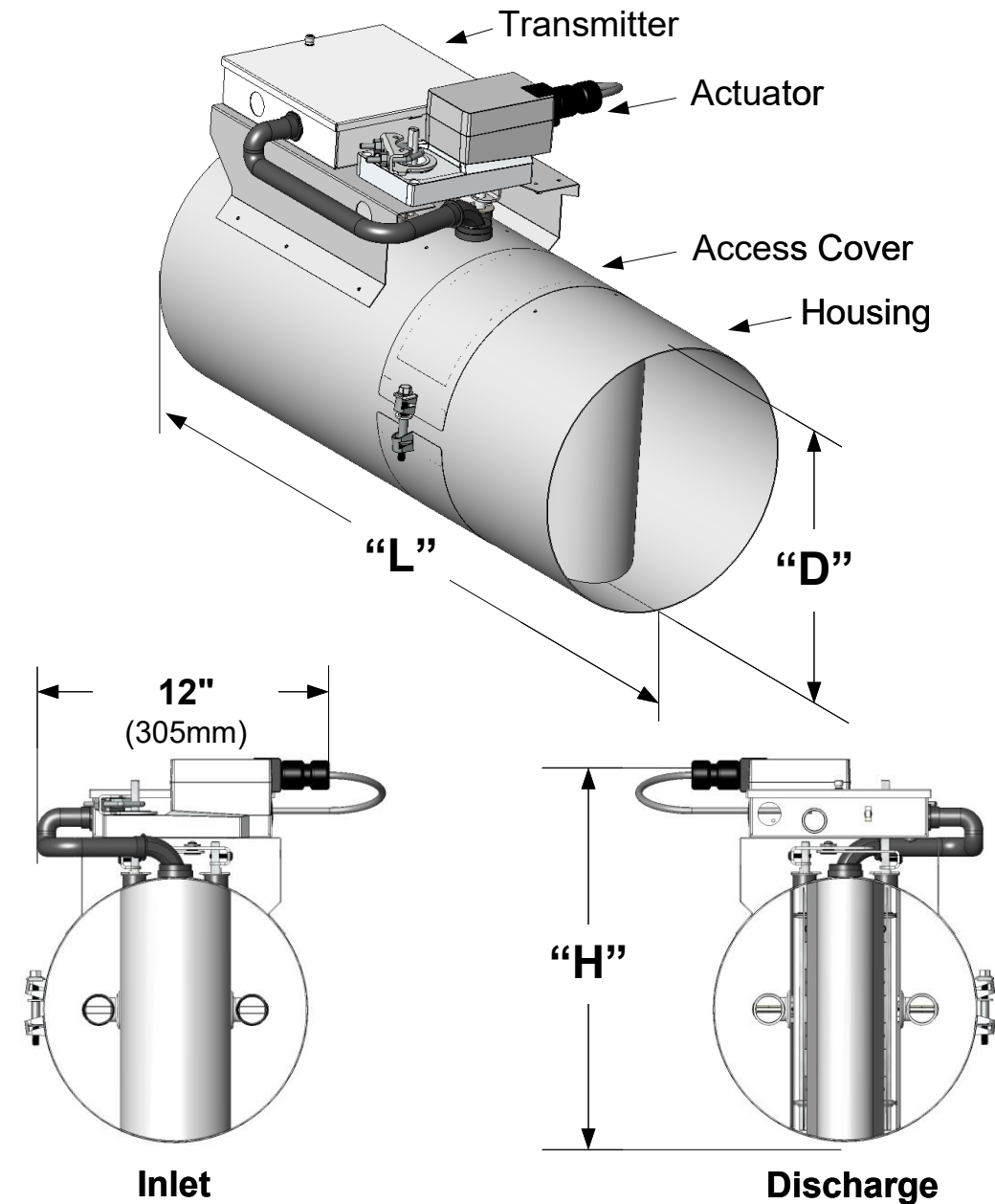

INSTALLATION INSTRUCTIONS

! WARNING: Use eye protection, cut-resistant gloves and clothing suitable for working with sheet metal. Failure to do so may result in personal injury.

1. Read all instructions prior to beginning installation.
2. Verify the tag number located on the valve label matches the HVAC schedule.
3. Locate the duct section which the valve is servicing and select a suitable mounting location for the valve. The recommended mounting position is vertical as shown in Figure 1. If vertical mounting is not possible and the valve is installed in a horizontal duct run, the valve shall be positioned with the transmitter on the top as shown in Figure 2.

NOTE: The AccuValve® does not require straight inlet duct runs to operate properly, however it's always best to locate the valve away from transitions and bends to minimize impact on system static pressure. Also be sure to select a location that will provide a minimum clearance of 14 inches (356 mm) unobstructed access to the transmitter, actuator and valve access cover.

4. Provide an opening in the selected duct section sized appropriately for the valve being installed.

NOTE: A slip-fit valve will require an opening approximately 2" (51mm) smaller than the valve length.

5. Install duct hangers within 12 inches (305 mm) from each end of the valve. Reference Sheet 1 for valve weights.

! WARNING: Use duct hangers and hardware designed to support the total load of valve and associated duct sections. Failure to do so may result in serious personal injury or death.

6. Install the valve into the duct in accordance with the Airflow Direction Label located on the valve. Position valve for easy access to the transmitter side and secure to duct per Figure 3.

NOTE: Screws, nuts, fasteners, duct sealant, and hangers are not provided by Accutrol LLC.

! CAUTION: Handle valve with care. Do not scratch the PFA coating on inside surfaces of valve and do not drive screws through valve housing.

Figure 1

Install in Vertical Duct

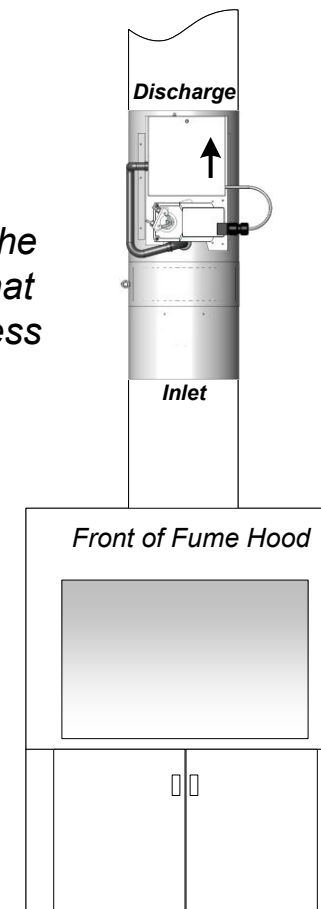
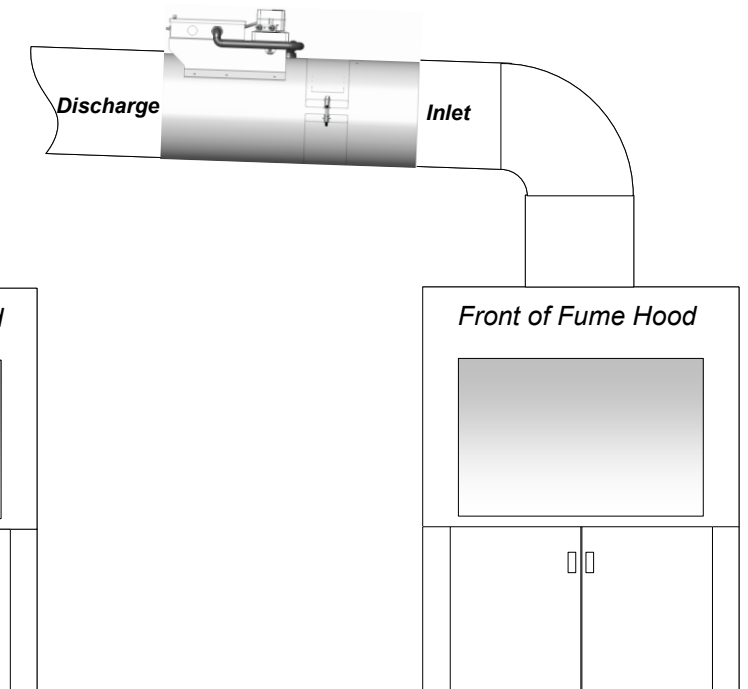

Figure 2

Position AccuValve with Transmitter at Top

NOTE: To reduce the potential for condensation pooling inside the duct or valve, the duct shall be pitched towards the fume hood.



Standard Slip-fit Valve Secured Using Draw Bands

(Draw Bands are Sold Separately)

After sealing joints with appropriate type of tape, secure both ends using draw band clamps.

NOTE: Install valve in ductwork with controller facing up as shown in Figure 2

14" (356mm) Keep-Out Zone

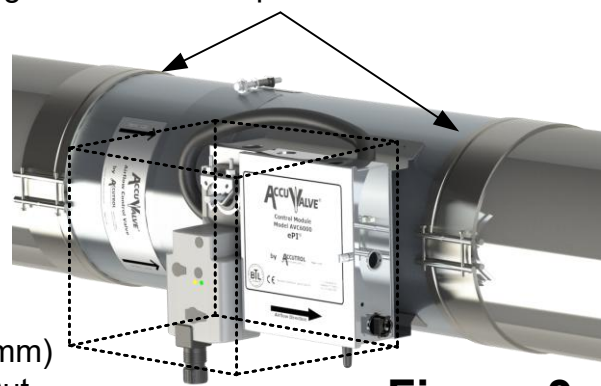

Figure 3

Reference Accutrol Draw Band Clamp Submittal Drawing for Details

Flanged Valve "Option F" Secured Using Companion Flanges

(Companion Flanges are Sold Separately)

Attaching Split Vanstone Flange to Accuvalve:

Join each Vanstone flange half together just below the rolled edge of the valve per figure 4 using the hardware provided. Tighten each nut and verify the Vanstone flange is captured onto the valve and can be freely rotated. Repeat on other end of the valve.

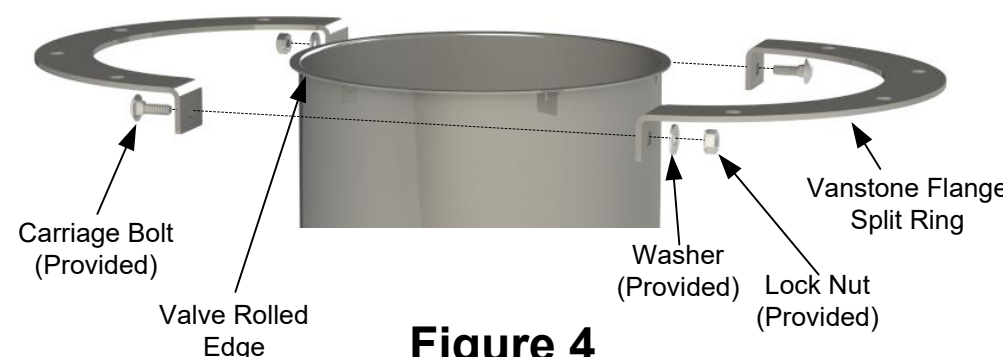
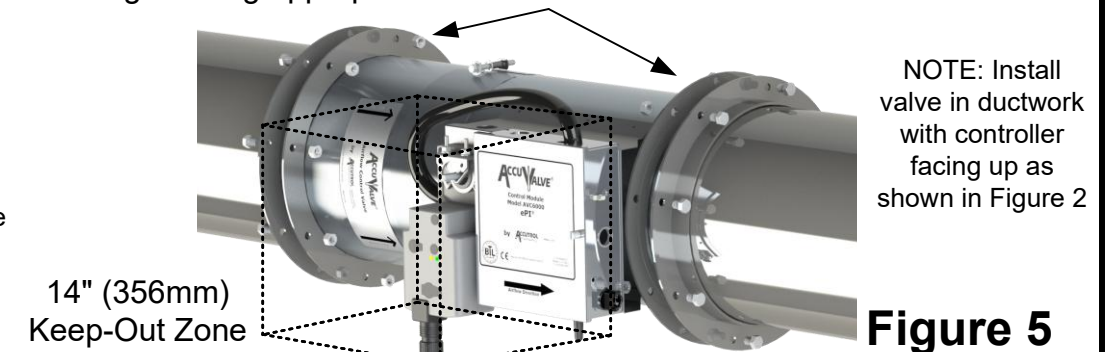

Figure 4

Attaching Vanstone Flange to Companion Flanges:

Install companion flanges to duct ends and secure to duct. Apply duct sealant and/or gasket to flange face. Install valve and rotate Vanstone flanges to align with bolt holes on the duct flanges. Secure flanges using appropriate hardware.



NOTE: Install valve in ductwork with controller facing up as shown in Figure 2

Figure 5

Reference Accutrol Vanstone Flange Submittal Drawing for Details

WIRING INSTRUCTIONS

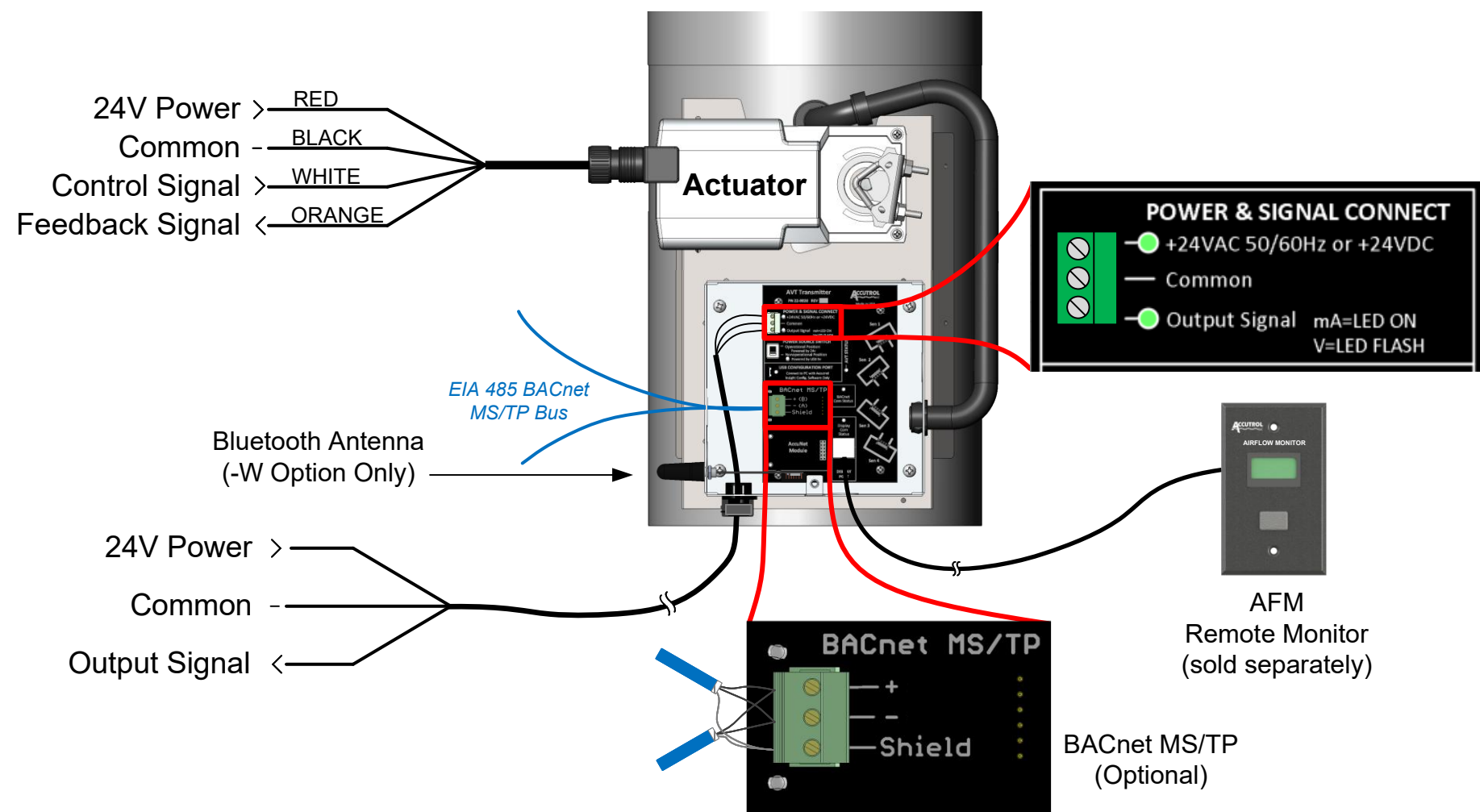

Transmitter and Actuator

Connect the power and signal wires to the Actuator and Transmitter per the diagram. For more details on the actuator, reference the appropriate actuator submittal drawing listed in the table below.

CAUTION: Maintain polarity if the power source is used to power multiple devices otherwise equipment may be damaged.

CAUTION: Do not use the transmitter enclosure as a junction box. The only wires entering the transmitter enclosure shall be wires connected to the transmitter otherwise equipment may be damaged.

Optional AccuNet Module

Reference AccuNet Field Manual.

Optional BACnet MS/TP Module

Connect the 2-wire EIA 485 BACnet MS/TP bus to the AVT6000 transmitter per the diagram. Network bias and EOL termination are not provided by the AVT6000.

Optional Wireless Bluetooth Module

Reference Wireless Bluetooth Field Manual.

Remote Monitor AFM (Sold Separately)

Plug one end of the factory cable into the back of the remote monitor and plug the other end into the AVT6000 Display Port.

TRANSMITTER ELECTRICAL SPECIFICATIONS

Power Supply: 24 VAC +/- 20% 50/60 Hz, 4 VA max (8.5 VA max with remote monitor)
24 VDC +/- 10% 1.5 W max (3.5 W max with remote display)

Output Signal: 0-20mA, 4-20mA, 0-10V, 2-10V, 0-5V, or 1-5V (Software Config.)
12-bit Resolution
Capable of driving 1K-ohm load

Configuration: USB Type C Connector, Wireless Bluetooth (Optional)

Power Source Switch: Selects alternate power source for configuration when main power is not available by drawing 5V from PC connected to USB config. port

BACnet MS/TP (Optional): EIA 485 2-wire BACnet MS/TP, Galvanically Isolated
Data Rates 9600, 19200, 38400, 57600, 76800 and 115200
1/8 Unit Load Receiver Input Impedance

Network bias and EOL Termination not provided within the Transmitter

Remote Monitor (Sold Separately): LCD, 2 lines x 8 characters with white LED backlight
Includes USB Configuration Port and Factory Cable

Terminal Plugs: 3-position, vertical pluggable, screw on top, wire size 12-30 AWG

WARNING: During installation, testing, servicing and troubleshooting of this product, it may be necessary to work with live electrical components. This work shall be performed by a licensed electrician or qualified individual who has been properly trained in handling live electrical equipment. Failure to follow all electrical safety precautions when exposed to live electrical components may result in serious injury or death.

ACTUATOR ELECTRICAL SPECIFICATIONS

For actuator specifications, reference the Actuator Drawing per table below.

AVT6000 Model	Actuator Type	Actuator Drawing #
AVT65XX-02	0-10V, Fail Last Position	20-0008
AVT65XX-03	2-10V, Fail Last Position	20-0009
AVT65XX-04	0-10V, Fail Open or Closed	20-0010
AVT65XX-05	2-10V, Fail Open or Closed	20-0011