

ACCUVALVE® MODEL AVR6000 SUBMITTAL

MODEL CODE

AVR6 - -

⚠ **WARNING: NOT FOR USE WITH PERCHLORIC ACID**

VALVE MATERIAL

(Housing / End Plate & Blades)

- 2 = 304SS / 304SS
- 3 = 316SS / 316SS
- 4 = ALUMINUM / 304SS
- 6 = 304SS / 304SS (HIGH TEMP VALVE)

SIZE

- 06 = 06" DIAMETER
- 08 = 08" DIAMETER
- 10 = 10" DIAMETER
- 12 = 12" DIAMETER
- 14 = 14" DIAMETER
- 18 = 12"x18" RECTANGULAR
- 24 = 12"x24" RECTANGULAR
- 36 = 12"x36" RECTANGULAR
- 48 = 12"x48" RECTANGULAR

MODEL CODE NOTES:

- 1) Blade seals are standard on all 6" valves, therefore -S option is not available for valve size -06.
- 2) Actuator Type "05" factory default is set to "fail open".
- 3) Reference the Flange Detail - Vanstone submittal drawing for round flanges
- 4) Reference the Flange Detail - Rectangular submittal drawing for rectangular flanges.

OPTIONS

- BLANK = NO OPTIONS
- F = FLANGES (REF NOTES 3 & 4)
- I = INSULATION
- S = TIGHT SHUT-OFF (REF NOTE 1)
- W = WIRELESS BLUETOOTH

ACTUATOR

- 03 = FAIL LAST POSITION (FLP), 2 SEC
- 05 = FAIL OPEN/CLOSED (FSP), 2 SEC
- 07 = FAIL LAST POSITION (FLP), 21 SEC

MATERIALS

Materials Exposed to the Airstream

Valve Material Code	(2) 304SS	(3) 316SS	(4) Aluminum	(6) 304SS HIGH TEMP
Housing	304L SS (20 GA.)	316L SS (20 GA.)	Alum 5052-H32 (18 GA.)	304L SS (20 GA.)
Compression Section	304L SS (20 GA.)	316L SS (20 GA.)	Alum 5052-H32 (16 GA.)	304L SS (20 GA.)
Static Regain Section	304L SS (20 GA.)	316L SS (20 GA.)	Alum 5052-H32 (18 GA.)	304L SS (20 GA.)
End Plate	304L SS (16 GA.)	316L SS (16 GA.)	304L SS (16 GA.)	304L SS (16 GA.)
Blades	304L SS (16 GA.)	316L SS (16 GA.)	304L SS (16 GA.)	304L SS (16 GA.)
Shafts	316L SS	316L SS	316L SS	316L SS
Shaft Bearings	Teflon	Teflon	Teflon	Teflon
Vortex Sensors	Polycarbonate Plastic, UL94-V0	Polycarbonate Plastic, UL94-V0	Polycarbonate Plastic, UL94-V0	303 SS
Sensor Tubing	Polyurethane (Ether-based)	Polyurethane (Ether-based)	Polyurethane (Ether-based)	Viton Rubber
Compression Seals	EPDM Rubber	EPDM Rubber	EPDM Rubber	Viton Rubber
Machine Screws	304 SS	316 SS	304 SS	304 SS
Rivets	304 SS	316 SS	304 SS	304 SS
Blade Seals (optional)	EPDM Rubber	EPDM Rubber	EPDM Rubber	Viton Rubber

OPERATING RANGE

Valve Model	Min. Flow Measured			Full Scale Range		
	CFM	L/S	CMH	CFM	L/S	CMH
AVR6X06-XX	30	14	51	315	149	535
AVR6X08-XX	80	38	136	800	378	1359
AVR6X10-XX	120	57	204	1300	613	2209
AVR6X12-XX	180	85	306	1790	845	3041
AVR6X14-XX	250	118	425	2750	1298	4672
AVR6X18-XX	260	123	442	3200	1510	5437
AVR6X24-XX	350	165	595	4000	1888	6796
AVR6X36-XX	520	245	883	6400	3020	10874
AVR6X48-XX	700	330	1189	8000	3775	13592

Temperature Range				
Valve Material Code	Airstream		Ambient	
	Min. Temp.	Max. Temp.	Min. Temp.	Max. Temp.
2, 3, 4	-20° F (-29° C)	165° F (74° C)	-20° F (-29° C)	125° F (52° C)
6	-20° F (-29° C)	375° F (191° C)	-20° F (-29° C)	125° F (52° C)

SIZE AND WEIGHT

Valve Model	Valve Dimensions (Reference Sheet 2)						Weight					
	"D" or "W"		"L"		"H"		Stainless Steel		Aluminum		Flange Add	
	in.	mm	in.	mm	in.	mm	Lbs.	kg	Lbs.	kg	Lbs.	kg
AVR6X06-XX	5.88	149	22	559	10	254	13	5.9	9	4.1	2.0	0.9
AVR6X08-XX	7.88	200	24	610	13	330	16	7.3	12	5.4	2.6	1.2
AVR6X10-XX	9.88	250	24	610	15	381	20	9.1	14	6.4	3.2	1.5
AVR6X12-XX	11.88	300	27	686	17	432	26	11.8	16	7.3	4.5	2.0
AVR6X14-XX	13.88	350	30	762	19	483	30	13.6	20	9.1	5.2	2.4
AVR6X18-XX	17.88	454	30	762	19	483	43	19.5	26	11.8	5.0	2.3
AVR6X24-XX	23.88	607	30	762	19	483	49	22.2	29	13.2	5.5	2.5
AVR6X36-XX	35.88	911	30	762	19	483	97	44	59	26.8	10.0	4.5
AVR6X48-XX	47.88	1216	30	762	19	483	109	49.2	69	31.3	11.0	5.0

SIZE AND WEIGHT NOTES:

- 1) Round valves with optional flanges "L" is 1/2" (13mm) less than standard valves



Accutrol Representative:

SUBMITTAL DRAWING

AccuValve® Model AVR6000

THIS DOCUMENT IS SUBJECT TO CHANGE WITHOUT NOTICE.
THIS DOCUMENT OR THE CONTENTS THEREOF SHALL NOT BE MODIFIED WITHOUT PRIOR WRITTEN PERMISSION BY ACCUTROL LLC.

DWG. NO: AVR6000 SUBMITTAL DWG

REVISION: H ECN: 3193

REV. DATE: 4-14-26 SHEET: 1 OF: 6

ROUND VALVE

- AVR6X06-XX
- AVR6X08-XX
- AVR6X10-XX
- AVR6X12-XX
- AVR6X14-XX

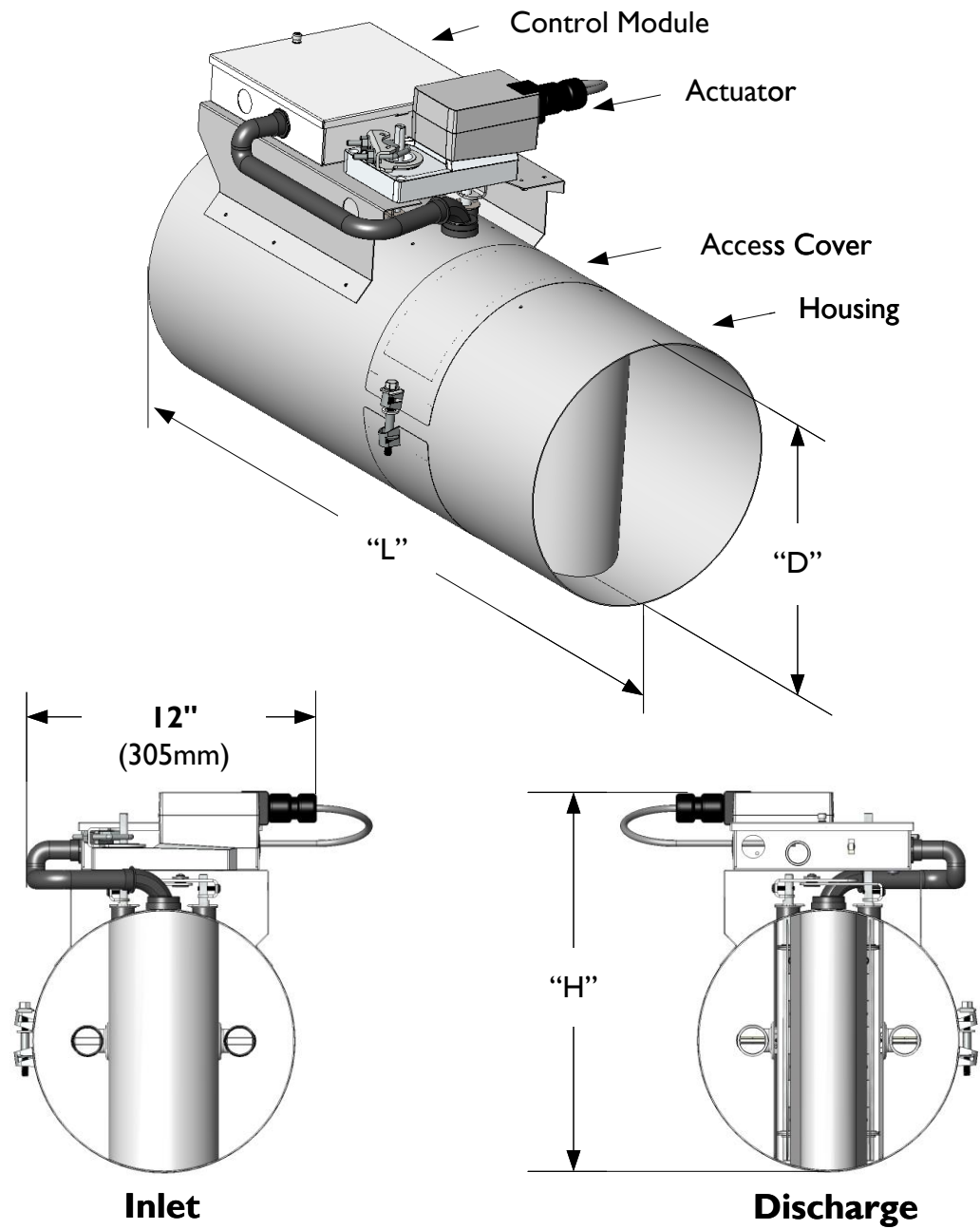

RECTANGULAR VALVE

- AVR6X18-XX
- AVR6X24-XX

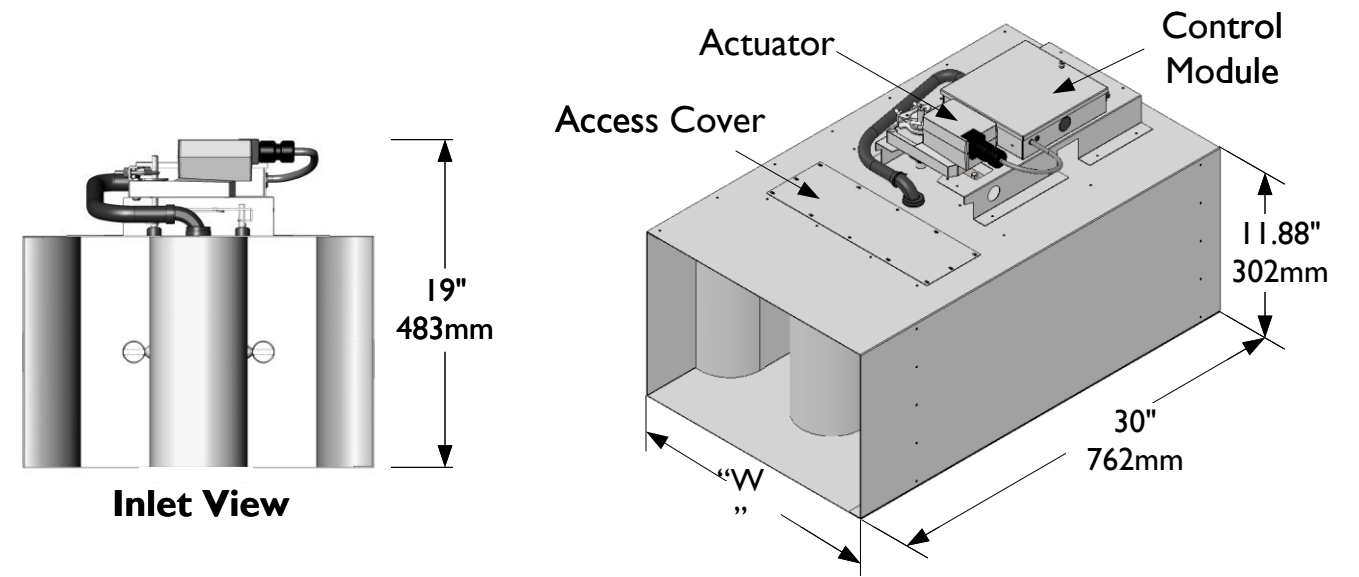

- AVR6X36-XX
- AVR6X48-XX

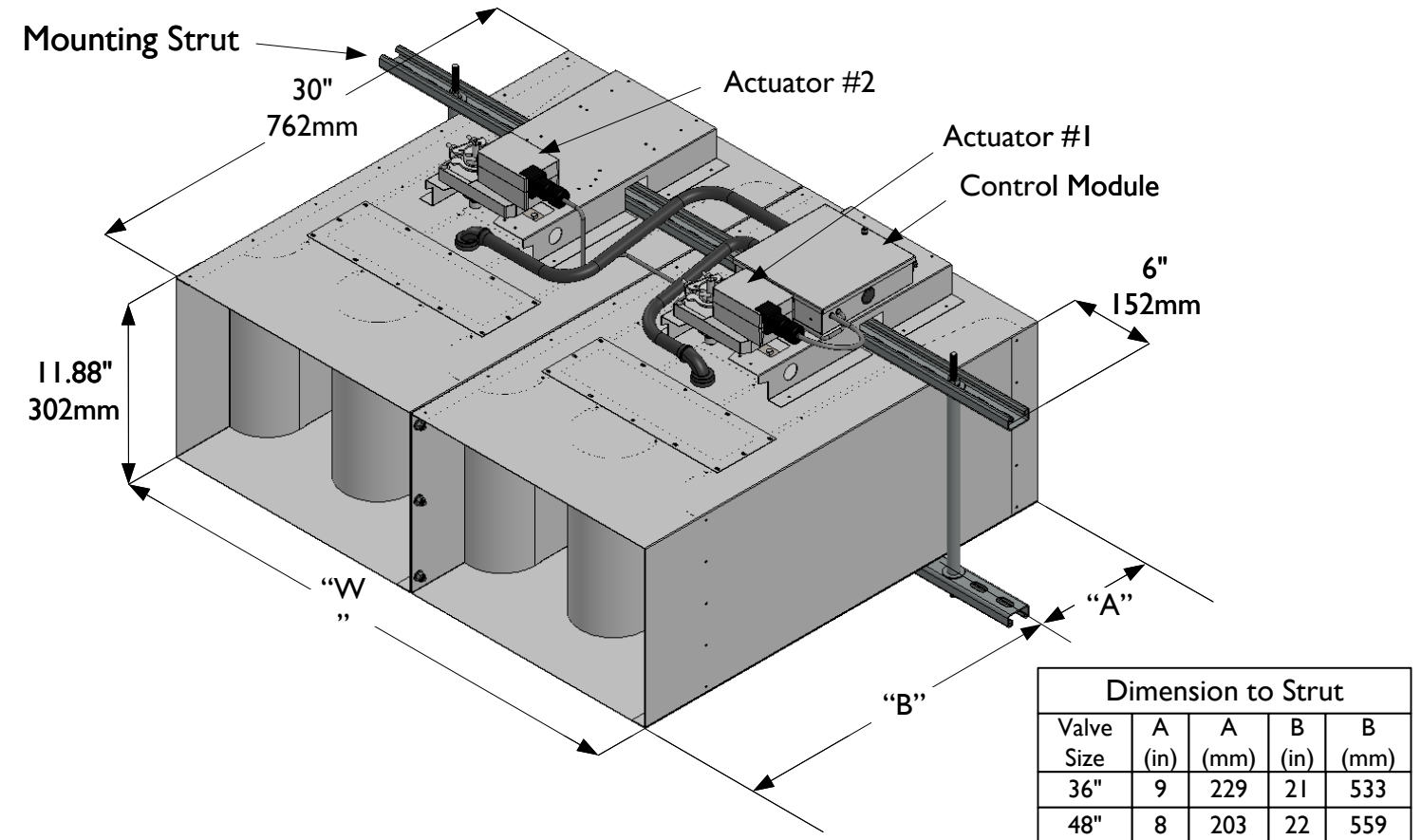

ROUND VALVE: INSTALLATION INSTRUCTIONS

WARNING: Wear eye protection, protective gloves and clothing suitable for working with sheet metal which may have sharp edges.

1. Read all instructions prior to beginning installation.

NOTE: For detailed installation instructions, refer to the AccuValve® Installation & Operation Manual.

2. Verify the tag number located on the valve label matches the HVAC schedule.

3. Locate the duct section which the valve is servicing and select a suitable mounting location for the valve.

NOTES: The AccuValve® does not require straight inlet duct runs to operate properly, however it's always best to locate the valve away from transitions and bends to minimize impact on system static pressure. Be sure to select a location that will provide a minimum clearance of 14 inches (356 mm) unobstructed access to the control module, actuator and valve access cover. The AccuValve® is not position sensitive. It can be installed in any plane or rotational axis without having impact on the performance.

4. Provide an opening in the selected duct section sized appropriately for the valve being installed.

NOTE: A slip-fit valve will require an opening approximately 2" (50.8 mm) smaller than the valve length, whereas a flanged valve will require an opening the same length as the valve. Reference Sheet 1 for valve dimensions.

5. Install duct hangers within 12 inches (305 mm) from each end of the valve. Reference Sheet 1 for valve weights.

WARNING: Use duct hangers and hardware designed to support the total load of valve and associated duct sections. Failure to do so may result in serious personal injury or death.

6. Install the valve into the duct in accordance with the Airflow Direction Label located on the valve. Position the valve for easy access to the controller side then secure to duct per the appropriate Figure below.

NOTE: Screws, nuts, fasteners, duct sealant, hangers, and gaskets are not provided by Accutrol LLC.

Standard Slip-fit Valve Secured Using Tek Screws

Seal joints using duct sealant and secure valve to duct at both ends using Tek screws.

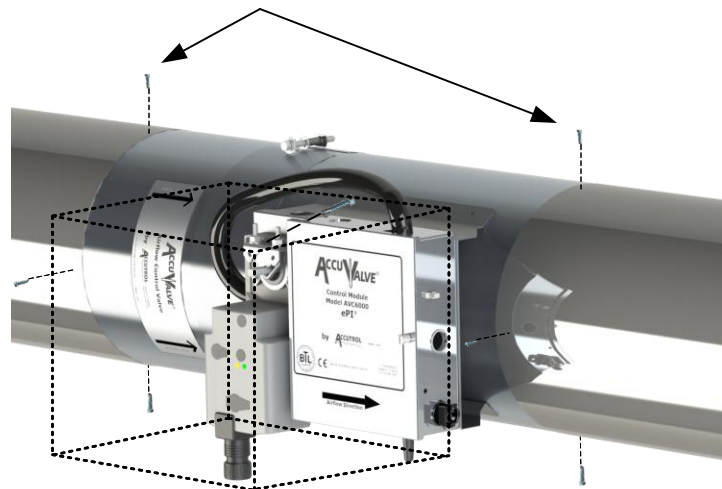

14" (356mm)
Keep-Out Zone

Figure 1

Standard Slip-fit Valve Secured Using Draw Bands

(Draw Bands are Sold Separately)

After sealing joints with appropriate type of tape, secure both ends using draw band clamps.

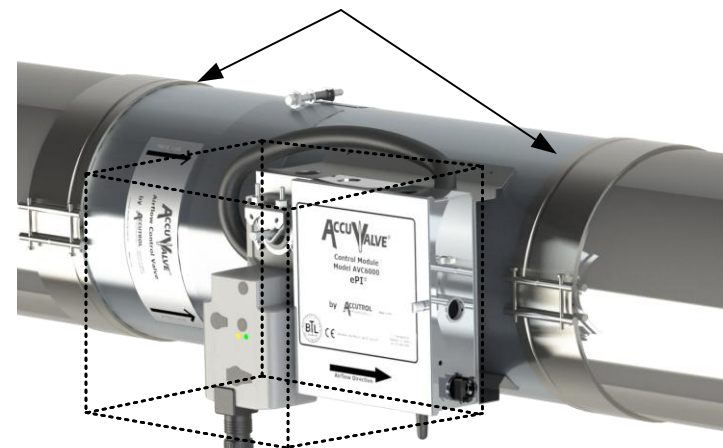

14" (356mm)
Keep-Out Zone

Figure 2

Reference Accutrol Draw Band Clamp Submittal Drawing for Details

Flanged Valve "Option F" Secured Using Companion Flanges

(Companion Flanges are Sold Separately)

Install companion flanges to duct ends and secure to duct. Apply duct sealant and/or gasket to flange face. Install valve and rotate Vanstone flanges to align with bolt holes on the duct flanges. Secure flanges using appropriate hardware.

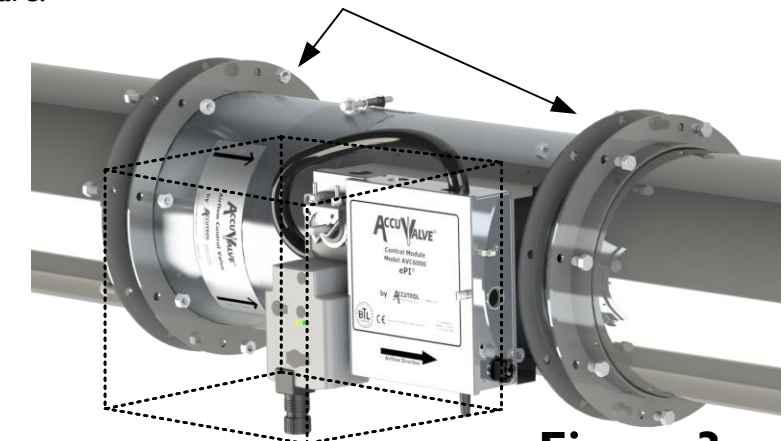

14" (356mm)
Keep-Out Zone

Figure 3

Reference Accutrol Vanstone Flange Submittal Drawing for Details

RECTANGULAR VALVE: INSTALLATION INSTRUCTIONS

1. Read all instructions completely before installing the valve.

⚠ WARNING: Wear eye protection, protective gloves and clothing suitable for working with sheet metal which may have sharp edges.

2. Verify the tag number located on the valve label matches the HVAC schedule.

3. Select optimum mounting location for the valve.

NOTE: The AccuValve® does not require straight inlet duct runs to operate properly, however it's always best to locate any duct device away from transitions and bends to minimize impact on system static pressure.

4. Allow a minimum clearance of 14 inches (356 mm) unobstructed access to the controller, actuator and valve access cover.

NOTE: Rectangular valves are normally installed with the "access side" facing downwards for easy access. However, the AccuValve® is not position sensitive. It can be installed in any plane or rotational axis without having impact on the performance.

5. To support the weight of the valve, install duct hangers within 12 inches (305 mm) of valve connections. The 12x36" and 12x48" valves include an integral mounting strut which shall be used to support the valve in addition to the duct hangers. Reference Sheet 1 for valve weights.

⚠ WARNING: Use duct hangers and hardware designed to support the total load of the valve and associated duct sections. Failure to do so may result in serious personal injury or death.

6. After the duct section is properly supported to carry the weight of the valve, install valve into the duct in accordance with the Airflow Direction Label located on the valve. Position valve so the controller, actuator and access cover are easily accessible. For 12x36" and 12x48" valves, attach the integral mounting bracket to threaded rod or duct hangers capable of supporting valve weight.

7. Reference the appropriate diagram to the right for installation details.

NOTE: Screws, nuts, fasteners, duct sealant, hangers, companion flanges and gaskets are not provided by Accutrol LLC.

RECTANGULAR VALVE: INSTALLATION DIAGRAMS

Figure 1

Standard Slip-fit Valve Using Tek Screws

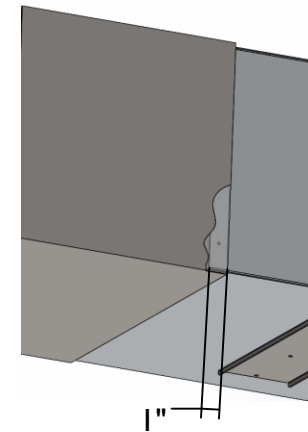

For slip-fit applications valve must be inserted at least 1" into ductwork to cover open holes on valve housing.

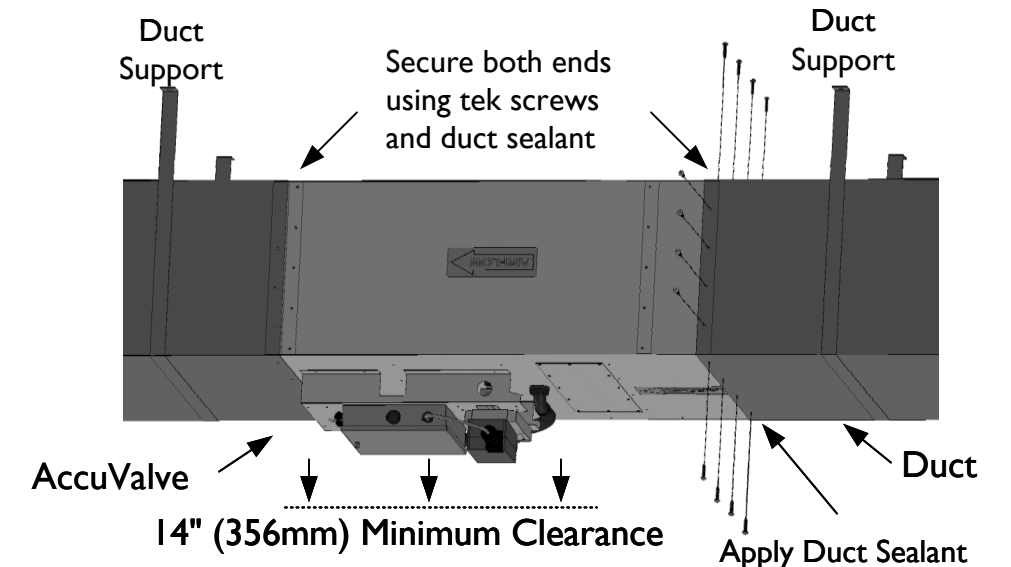

Figure 2

Flanged Valve "Option F" Using Companion Flanges

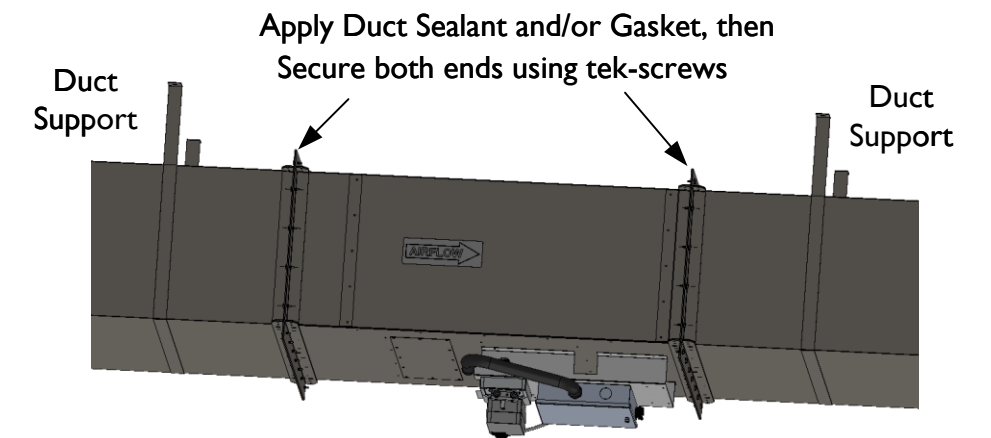
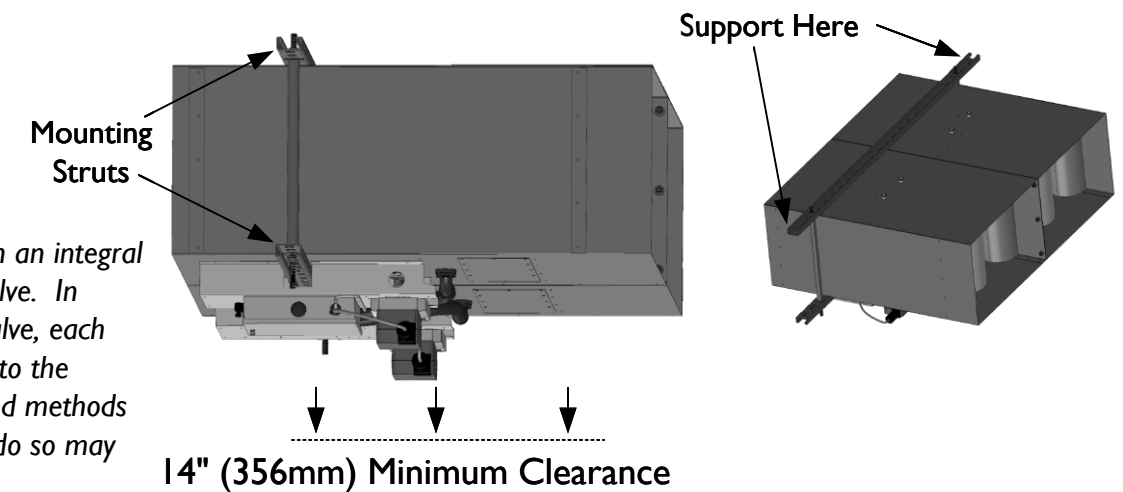

Figure 3

12x36" and 12x48" Valves

⚠ WARNING: Dual valves are provided with an integral mounting strut to help support the weight of the valve. In addition to supporting the duct within 12" of the valve, each end of the integral mounting strut shall be secured to the building structure using properly rated hardware and methods in accordance with local building codes. Failure to do so may result in serious personal injury or death.



CONTROL MODULE

CAUTION: Do not use the control module enclosure as a junction box for other equipment wiring otherwise equipment may be damaged.

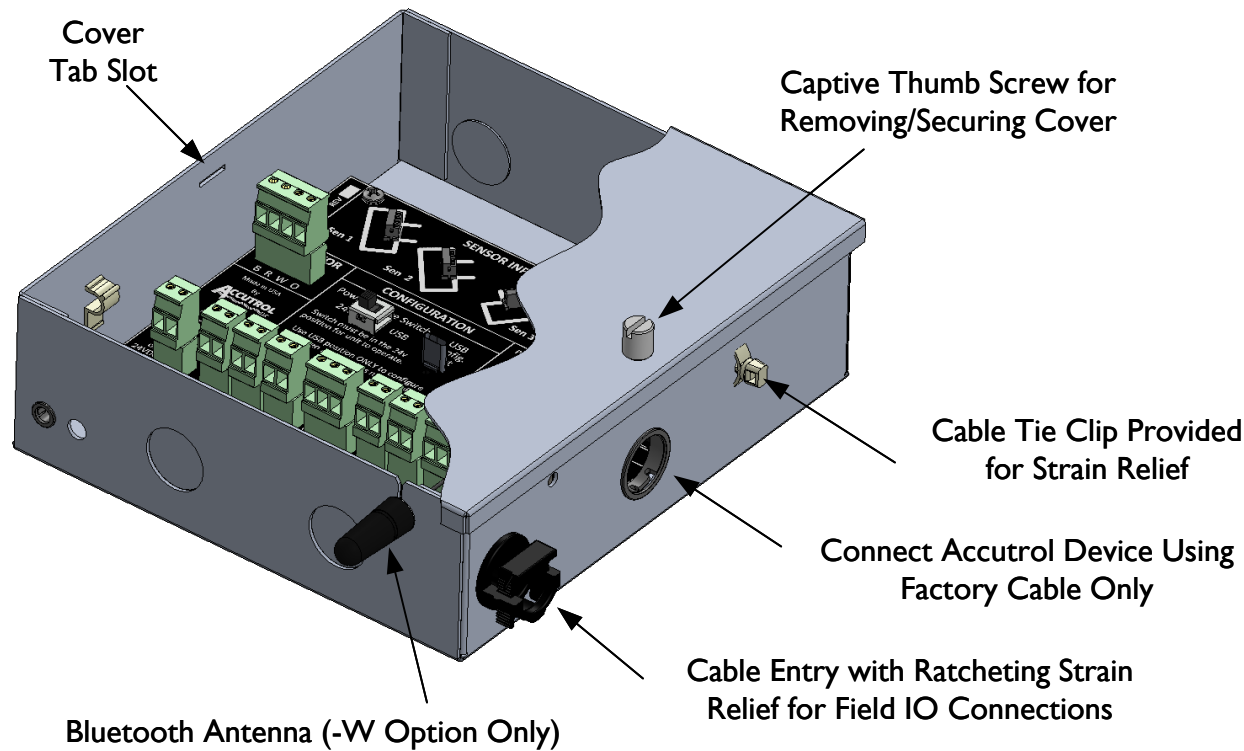

Note: If a conduit connection is required, the strain relief fitting and bushing can be removed and replaced with a .875" (22mm) conduit fitting. (Provided by Others)

WIRING INSTRUCTIONS

1. Remove cover.
2. Route cables through the strain-relief fitting into the enclosure.
3. Remove terminal block plug(s) and connect wires to the appropriate terminals.
4. Secure terminal screws and reinstall plug(s).
5. Insert the ratcheting strain relief over cable(s) and push down until snug.
6. Reinstall cover and secure thumb screw.

ELECTRICAL SPECIFICATIONS

- INPUTS:** (3) Dedicated Analog Inputs
- AI-1 (DTS): Supply Air Discharge Temperature Signal, from Duct Temperature Sensor
Signal Type (Software Selectable)
Voltage: 0-10v Range, Input Impedance = 100K ohms
Current: 0-20mA Range, Input Impedance = 500 ohms
Resistance: 0-20K ohm Range, 500uA Internal Current Source
 - AI-2 (GEV): General Exhaust Airflow Volume Signal, from AVT AccuValve
Signal Type (Software Selectable)
Voltage: 0-10v Range, Input Impedance = 100K ohms
Current: 0-20mA Range, Input Impedance = 500 ohms
 - AI-3 (FHV): Fume Hood Exhaust Airflow Volume Signal, from AVC AccuValve
Signal Type (Software Selectable)
Voltage: 0-10v Range, Input Impedance = 100K ohms
Current: 0-20mA Range, Input Impedance = 500 ohms
- (2) Dedicated Digital Inputs
Setpoint Mode Selectors
Signal Type: Dry Contact Only

- OUTPUTS:** (2) Dedicated Analog Outputs
- AO-1 (RHV): Reheat Valve Control Signal, to Reheat Valve Actuator Control Input
 - AO-2 (GEV): General Exhaust Control Signal, to AVT AccuValve Actuator Control Input
Signal Types (Software Selectable); Capable of Driving 1K ohm Load
Voltage: 0-10V, 2-10V, 0-5V or 1-5V
Current: 0-20mA or 4-20mA
- Alarm Output
DPDT Relay, NC/NO Contacts, 1A @ 30VDC

NETWORK: BACnet MS/TP
EIA 485 2-wire, Receiver Impedance: 1/4 unit load
Network Bias and Termination are NOT provided internally by the AVR Control Module

CONFIGURATION: USB Type C Port, Wireless Bluetooth (Optional)
Connect to Computer running AccuValve Insight Software

DEVICE PORT: RJ-45 Port, Connect to Accutrol Device using Factory-Supplied Cable Only

IO TERMINALS: Removable Vertical Plugs, 2 & 3 Position, See Sheet 6 for Wire Size Range

POWER: 24VAC +/-20%, 50/60Hz. (Class 2 Power Source) or 24VDC +/-10%

Actuator Type	Maximum Power Requirements	
	Valve Size; 06-24	Valve Size; 36 & 48
3 or 5	30VA or 17W	53VA or 30W
7	13VA or 7W	19VA or 12W

CAUTION: Maintain polarity if power source is used to power multiple devices otherwise equipment may be damaged.



Accutrol Representative:

SUBMITTAL DRAWING

AccuValve® Model AVR6000

THIS DOCUMENT IS SUBJECT TO CHANGE WITHOUT NOTICE.
THIS DOCUMENT OR THE CONTENTS THEREOF SHALL NOT BE MODIFIED WITHOUT PRIOR WRITTEN PERMISSION BY ACCUTROL LLC.

DWG. NO:	AVR6000 SUBMITTAL DWG		
REVISION:	H	ECN:	3193
REV. DATE:	4-14-26	SHEET:	5 OF: 6

WIRING DIAGRAM

Power Source

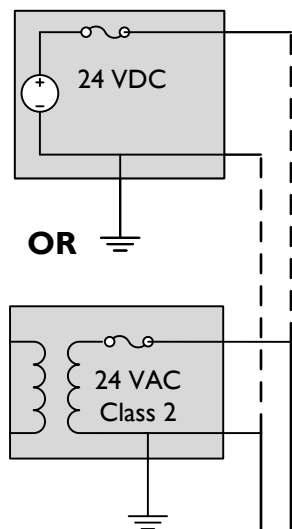

AVR6000 Control Module SAV

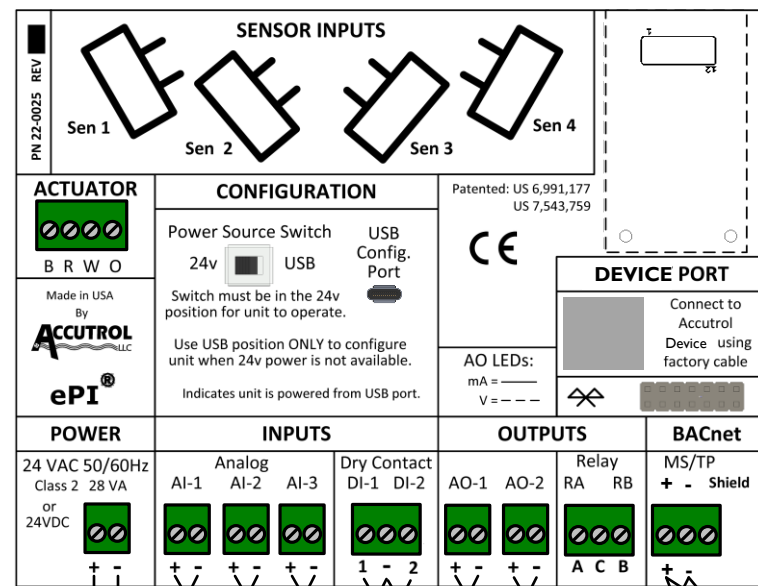

or

Factory Cable

To Next BACnet Device

Twist Shields Together and Tape Back or Connect to "Shield" Terminal Notes 4, 5

From Previous BACnet Device

Discharge Air Temp Sensor Accutrol Model DTS100

Other Third Party Duct Temperature Sensors May Be Used

CABLE SPECIFICATIONS		
AVR CONNECTION	CABLE TYPE	NOTE
24V POWER	16-18 gauge, 2-conductor	1, 2
ANALOG INPUTS	18-22 gauge, shielded twisted pair	
DRY CONTACT INPUTS	18-22 gauge, twisted pair	
ANALOG OUTPUTS	18-22 gauge, shielded twisted pair	6
RELAY OUTPUTS	18-22 gauge, twisted pair	
BACnet MS/TP	22-24 gauge, shielded twisted pair, low capacitance	3,4
DEVICE PORT	Factory cable provided with ARS or ADS room temp sensor	
ACCUNET NETWORK	22-24 gauge, shielded twisted pair, low capacitance	3,4

- NOTES:**
- Always consult local building codes and project specifications for wiring requirements.
 - CAUTION: Maintain polarity if power source is used to power multiple devices otherwise equipment may be damaged.
 - COMMUNICATIONS CABLE: Use Windy City Wire # 042002 or equivalent.
 - END OF LINE TERMINATION: Install 120-ohm resistors across +/- terminals on the first and last device on the network segment. Failure to do so will result in unreliable communications.
 - Cable Shield Shall be Connected at Single Point to Earth Ground
 - Electric reheats can induce EMI onto cables which can cause latch-up on connected devices. To reduce EMI, use shielded cable and ground the shield on one end only. Clamp-on ferrites can also be installed over the signal cables to reduce EMI.

