

ACCUVALVE® MODEL AVC6500 SUBMITTAL

MODEL CODE

! WARNING: NOT FOR USE WITH PERCHLORIC ACID

AVC6 5 - - -

VALVE HOUSING MATERIAL

5 = PFA COATED 304SS, 20 GAUGE

SIZE

08 = 08" DIAMETER
10 = 10" DIAMETER
12 = 12" DIAMETER
14 = 14" DIAMETER

OPTIONS

BLANK = NO OPTIONS
A = ACCUNET®
F = FLANGES (NOTE 2)
W = WIRELESS BLUETOOTH

ACTUATOR

03 = FAIL LAST POSITION (FLP), 2 SEC
05 = FAIL OPEN/CLOSED (FSP), 2 SEC

MODEL CODE NOTES:

1. Actuator Type "5" factory default is set to "fail open".
2. Split ring Vanstone Flanges

OPERATING RANGE

Valve Model	Min. Flow Measured			Full Scale Range		
	CFM	L/S	CMH	CFM	L/S	CMH
AVC6508-XX	80	38	136	800	378	1359
AVC6510-XX	120	57	204	1300	613	2209
AVC6512-XX	180	85	306	1790	845	3041
AVC6514-XX	250	118	425	2750	1298	4672

MATERIALS

Materials Exposed to the Airstream	
Housing	PFA Coated, 304 Stainless Steel
Compression Section	PFA Coated, 304 Stainless Steel
Static Regain Section	PFA Coated, 304 Stainless Steel
End Plate	PFA Coated, 304 Stainless Steel
Blades	PFA Coated, 304 Stainless Steel
Shafts	PFA Coated, 316 Stainless Steel
Shaft Bearings	Teflon®
Vortex Sensors	Kynar® PVDF
Sensor Tubing	Viton Rubber
Compression Seals	Viton Rubber
Machine Screws	FEP Coated, 304 Stainless Steel
Rivets	FEP Coated, 304 Stainless Steel
Optional Flanges	FEP Coated, 304 Stainless Steel

SIZE AND WEIGHT

Valve Model	Valve Dimensions						Weight			
	"D"		"L"		"H"		Stainless Steel		Flange Add	
	in.	mm	in.	mm	in.	mm	Lbs.	kg	Lbs.	kg
AVC6508-XX	7.88	200	24	610	13	330	16	7.3	2.6	1.2
AVC6510-XX	9.88	250	24	610	15	381	20	9.1	3.2	1.5
AVC6512-XX	11.88	300	27	686	17	432	26	11.8	4.5	2.0
AVC6514-XX	13.88	350	30	762	19	483	30	13.6	5.2	2.4

SIZE AND WEIGHT NOTES:

1) Round valves with optional flanges "L" is 1/2" (13mm) less than standard valves

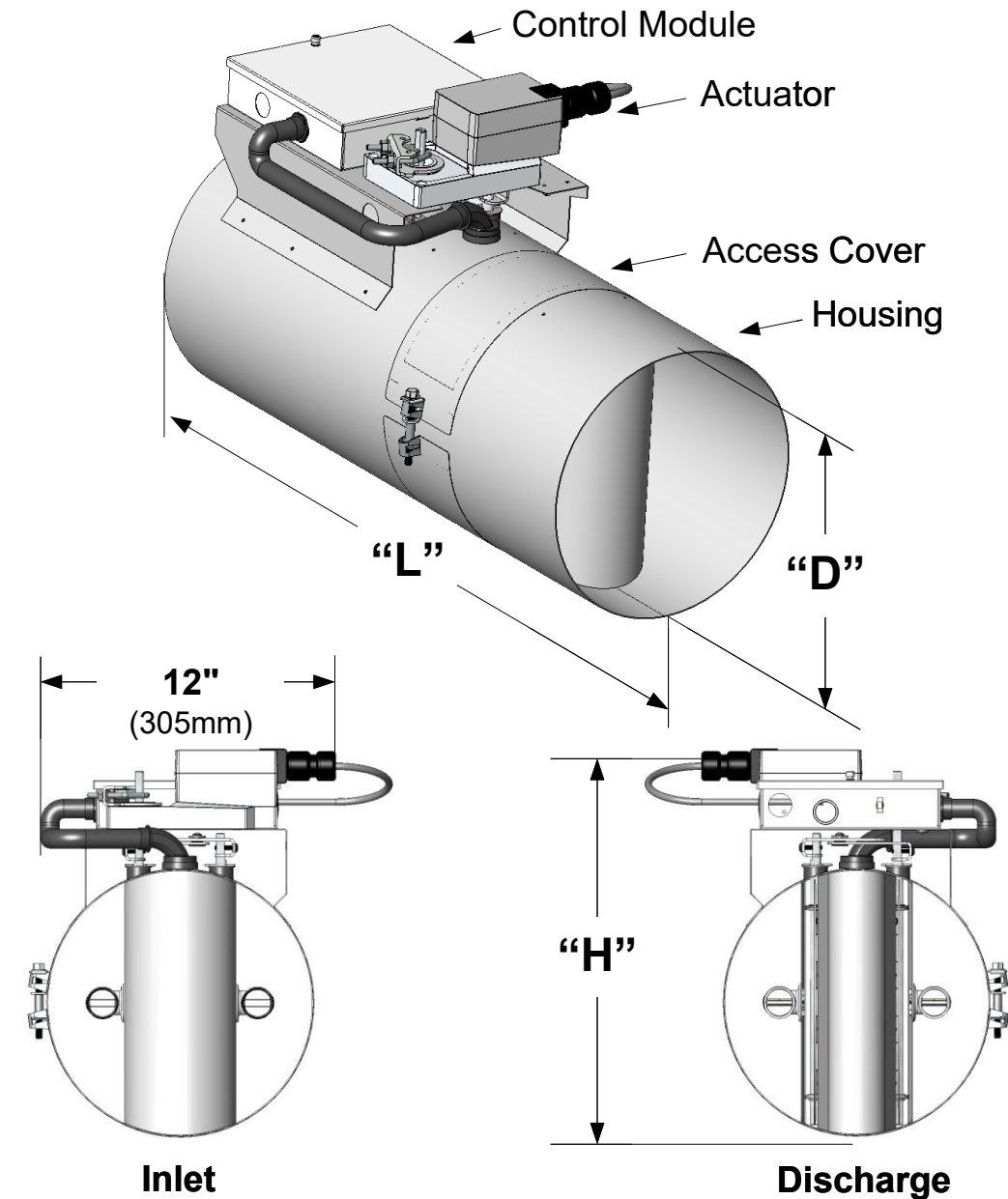

INSTALLATION INSTRUCTIONS

! WARNING: Use eye protection, cut-resistant gloves and clothing suitable for working with sheet metal. Failure to do so may result in personal injury.

1. Read all instructions prior to beginning installation.
2. Verify the tag number located on the valve label matches the HVAC schedule.
3. Locate the duct section which the valve is servicing and select a suitable mounting location for the valve. The recommended mounting position is vertical as shown in Figure 1. If vertical mounting is not possible and the valve is installed in a horizontal duct run, the valve shall be positioned with the controller on the top as shown in Figure 2.

NOTE: The AccuValve® does not require straight inlet duct runs to operate properly, however it's always best to locate the valve away from transitions and bends to minimize impact on system static pressure. Also be sure to select a location that will provide a minimum clearance of 14 inches (356 mm) unobstructed access to the control module, actuator and valve access cover.

4. Provide an opening in the selected duct section sized appropriately for the valve being installed.

NOTE: A slip-fit valve will require an opening approximately 2" (51mm) smaller than the valve length.

5. Install duct hangers within 12 inches (305 mm) from each end of the valve. Reference Sheet 1 for valve weights.

! WARNING: Use duct hangers and hardware designed to support the total load of valve and associated duct sections. Failure to do so may result in serious personal injury or death.

6. Install the valve into the duct in accordance with the Airflow Direction Label located on the valve. Position valve for easy access to the control module side and secure to duct per Figure 3.

NOTE: Screws, nuts, fasteners, duct sealant, and hangers are not provided by Accutrol LLC.

! CAUTION: Handle valve with care. Do not scratch the PFA coating on inside surfaces of valve and do not drive screws through valve housing.

Figure 1

Install in Vertical Duct

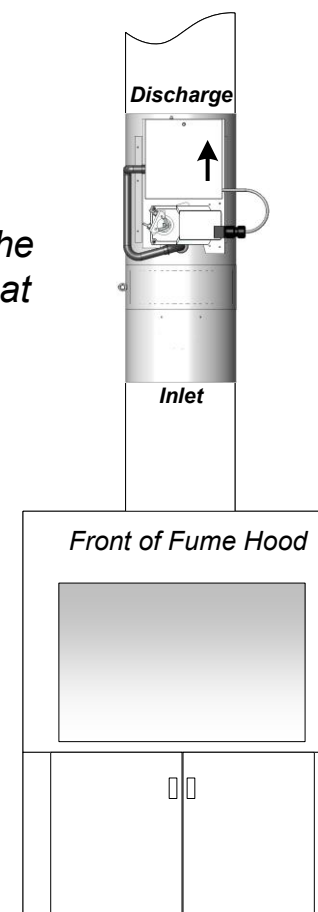
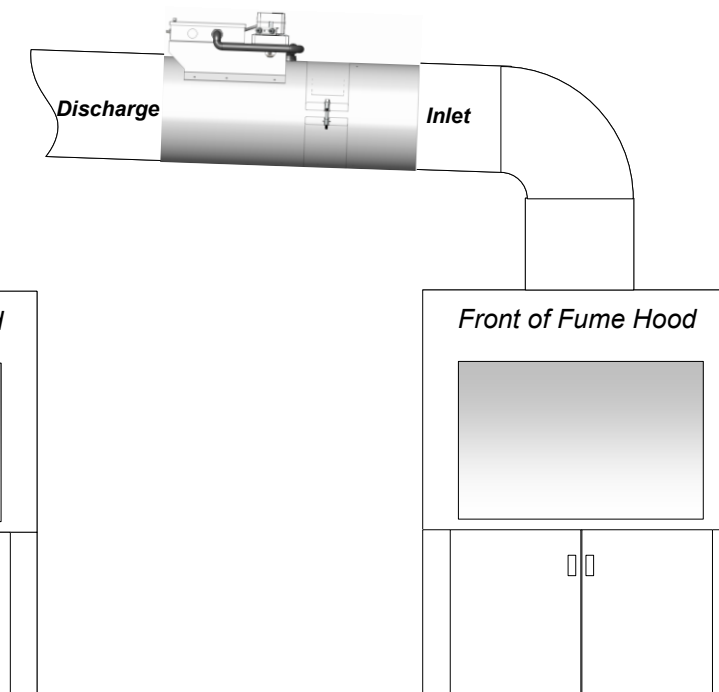

Figure 2

Position AccuValve with Controller at Top

NOTE: To reduce the potential for condensation pooling inside the duct or valve, the duct shall be pitched towards the fume hood.



Standard Slip-fit Valve Secured Using Draw Bands

(Draw Bands are Sold Separately)

After sealing joints with appropriate type of tape, secure both ends using draw band clamps.

NOTE: Install valve in ductwork with controller facing up as shown in Figure 2

14" (356mm) Keep-Out Zone

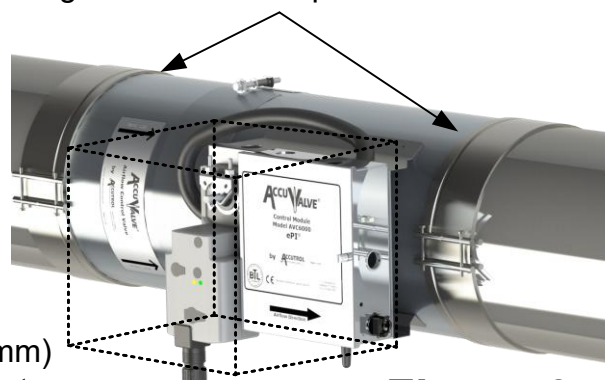

Figure 3

Reference Accutrol Draw Band Clamp Submittal Drawing for Details

Flanged Valve "Option F" Secured Using Companion Flanges

(Companion Flanges are Sold Separately)

Attaching Split Vanstone Flange to Accuvalve:

Join each Vanstone flange half together just below the rolled edge of the valve per figure 4 using the hardware provided. Tighten each nut and verify the Vanstone flange is captured onto the valve and can be freely rotated. Repeat on other end of the valve.

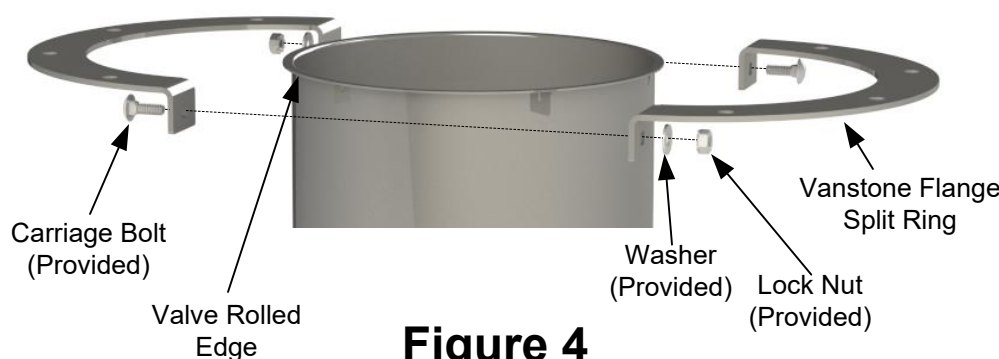
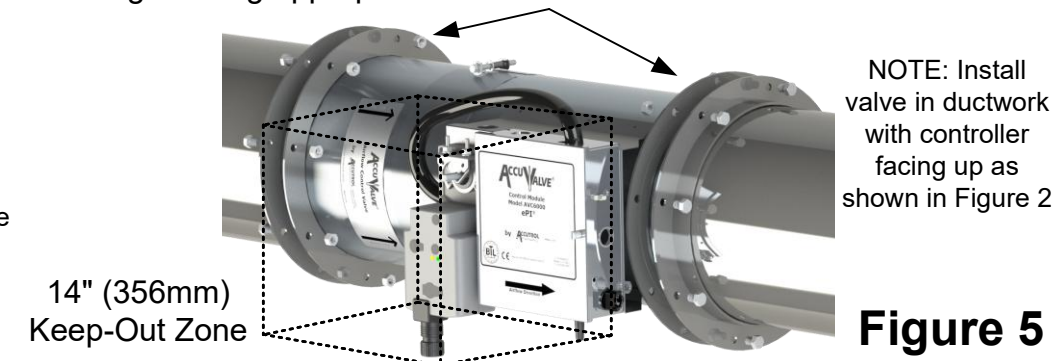

Figure 4

Attaching Vanstone Flange to Companion Flanges:

Install companion flanges to duct ends and secure to duct. Apply duct sealant and/or gasket to flange face. Install valve and rotate Vanstone flanges to align with bolt holes on the duct flanges. Secure flanges using appropriate hardware.



NOTE: Install valve in ductwork with controller facing up as shown in Figure 2

Figure 5

Reference Accutrol Vanstone Flange Submittal Drawing for Details

CONTROL MODULE

NOTE: Do not use controller enclosure as junction box for other equipment

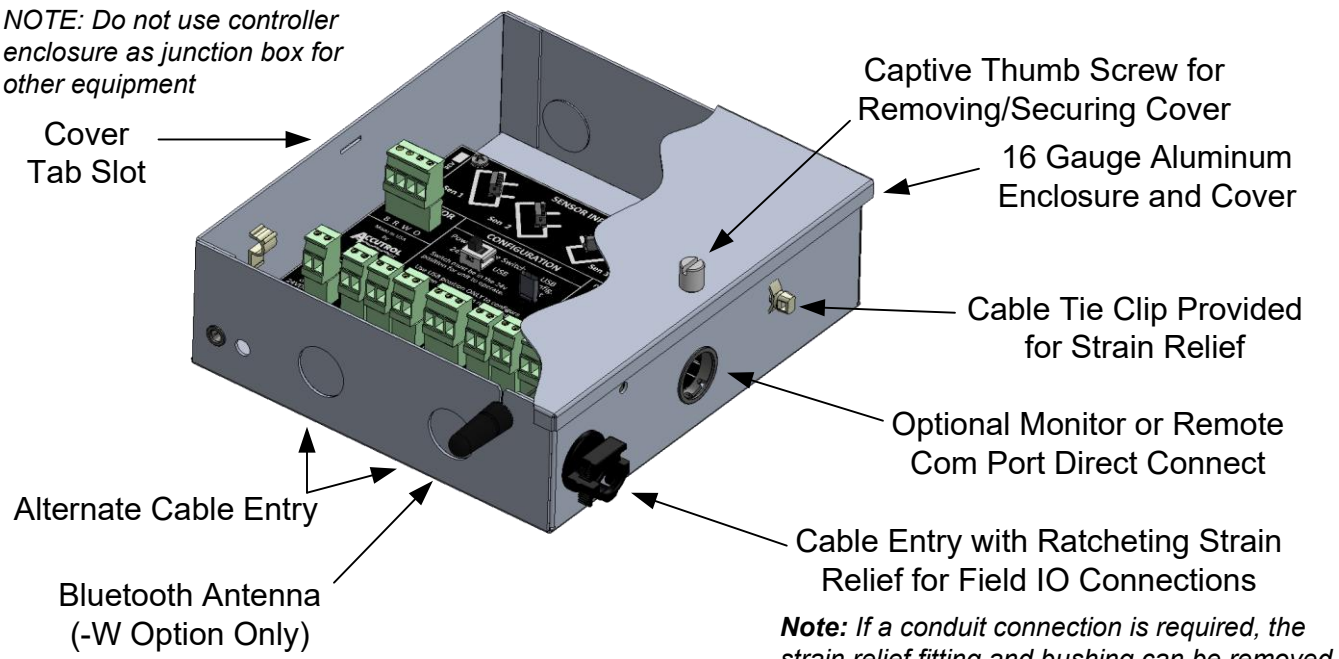

Wiring Instructions

1. Remove cover.
2. Route cables through the strain-relief fitting into the enclosure.
3. Remove terminal block plug(s) and connect wires to the appropriate terminals.
4. Secure terminal screws and reinstall plug(s).
5. Insert the ratcheting strain relief over cable(s) and push down until snug.
6. Reinstall cover and secure thumb screw.

WIRING DIAGRAM

NOTE: Connections will vary based on application. For detailed wiring instructions, use this drawing in conjunction with the job-specific wiring diagrams.

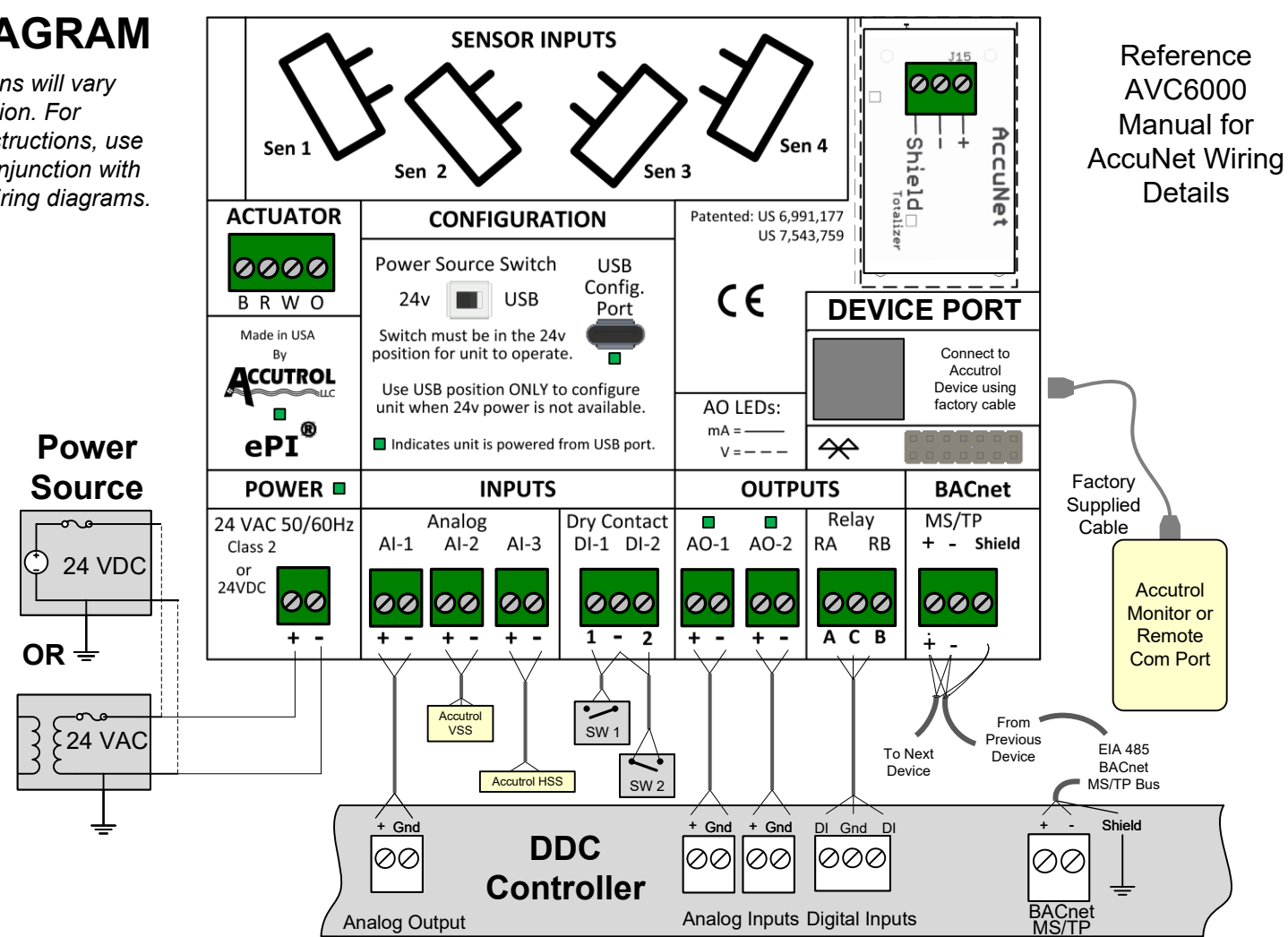

CAUTION: Maintain polarity if power source is used to power multiple devices otherwise equipment may be damaged.

ELECTRICAL SPECIFICATIONS

POWER: 24vAC +/-20%, 50/60Hz. (Class 2 Power Source) or 24vDC +/-10%.

Actuator Type	MAX POWER, Valve Sizes 06" through 24"			MAX POWER, Valve Sizes 36" through 48"		
	NO	WITH FHM1	WITH FHM3	NO	WITH FHM1	WITH FHM3
3	28VA or 16W	31VA or 17W	34VA or 19W	51VA or 29W	54VA or 30W	57VA or 32W
5	27VA or 14W	30VA or 15W	33VA or 17W	49VA or 25W	52VA or 26W	55VA or 28W

INPUTS:

Analog Inputs: AI-1, AI-2 and AI-3 (Software Selectable)
 Voltage: 0-10v Range, Input Impedance = 100K ohms
 Current: 0-20mA Range, Input Impedance = 500 ohms
 Resistance: 0-20K Range, 500uA Internal Current Source

Digital Inputs: 2 dry-contact inputs

OUTPUTS:

Analog Outputs AO-1, AO-2 (software selectable): 0-20mA, 4-20mA, 0-10v, 2-10v, 0-5v or 1-5v
 V-out capable of driving 1 K-ohm load @ 10v, I-out capable of driving 1K-ohm load

Alarm Output: DPDT Relay, NC/NO Contacts, 1A @ 30vDC or 0.3A @ 125 vAC

RS-485: EIA 485 BACnet MS/TP 2-wire, Receiver Impedance: 1/4 unit load
 Note: Network bias and field termination are NOT provided by the AVC Control Module

MONITOR PORT, RJ-45: Connect to Accutrol monitor or remote com port. Connect using factory supplied cable only

CONFIGURATION PORT: USB Type C, Wireless Bluetooth (Optional)

IO TERMINAL PLUGS: 2 & 3 position, vertical pluggable, screw access on top, wire size range 12-30 AWG



Accutrol Representative:

SUBMITTAL DRAWING

PFA Coated, Round AccuValve®

Model AVC6500

THIS DOCUMENT IS SUBJECT TO CHANGE WITHOUT NOTICE. THIS DOCUMENT OR THE CONTENTS THEREOF SHALL NOT BE MODIFIED WITHOUT PRIOR WRITTEN PERMISSION BY ACCUTROL LLC.

DWG. NO:	AVC6500 SUBMITTAL DWG		
REVISION:	K	ECN:	3193
REV. DATE:	4-14-26	SHEET:	3 OF: 3